



AETHON TUG T3XL Autonomous Mobile Robot

Product Description

The TUG T3XL from Aethon is an enhanced payload capacity smart autonomous mobile robot that automates the transport of materials and supplies in commercial environments. The total capacity is 1,400 lbs (635 kg) and can carry carts 48" (122cm) long. TUG is different from traditional AGV systems in that it requires no infrastructure for navigation.

- 24x7 Improved Productivity
- Auto docks and auto charges
- Automatic drop off and pickup of carts
- Can travel on irregular concrete floors
- Navigates on internal map of facility using laser
- Has multiple dispatch modes:
 - Scheduled
 - Touchscreen ad-hoc
 - Multi-stop "milk runs"
 - Handheld ad-hoc requests
 - Manufacturing system messages

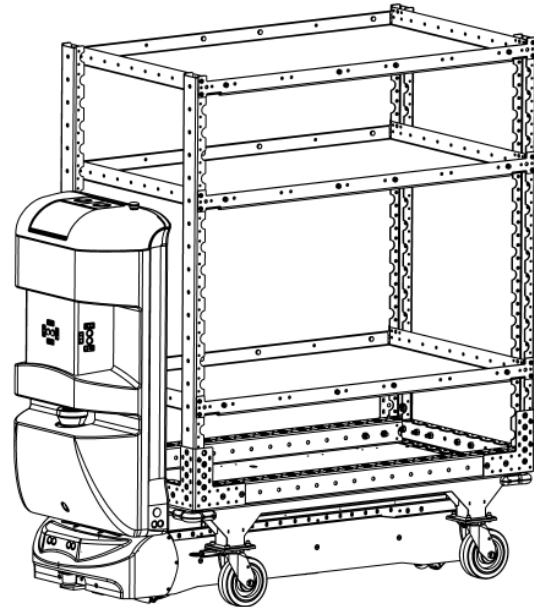

Specifications

Specification	
Maximum Carrying Capacity	1,400 lbs / 635kg
Battery Run Time	10 hours with intermittent charging
Battery Technology	Valve-Regulated Lead-Acid (VRLA)
Cart Length	48 Inches / 122 cm
Drive System	Omnidirectional 4 wheel driven
Navigation and Obstacle Detection	Real-time multi-LIDAR, sonar and infrared sensors
Communications	WiFi or 900MHz
Support	Locally hosted or remote to Aethon Command Center via secure encrypted VPN
Turning Radius	Rotate about center, front or rear
Docking Station Width	24" (61cm) plus 12"(30.5cm) clearance
Environmental	Interior use
Travel Speed	30" (76 cm) per second

Standards Compliance

- EN 12100:2010, EN 60204-1:2006+A1:2009, IEC 60034-1:2004-04
- EN 61000-6-4:2007; EN 61000-6-2:2005; EN 60601-1-2:2007, EN 55022
- EN 301 489-1, EN 301 489-17
- FCC CFR 47, Part 15; ICES-001; Australian RCM Compliance
- ETSI EN 300 220-1 V2.4.1 & ETSI EN 300 220-2 V2.4.1
- EN 300 328 1.7.1, EN 301 893 1.6.1

Full Omnidirectional Motion Capability

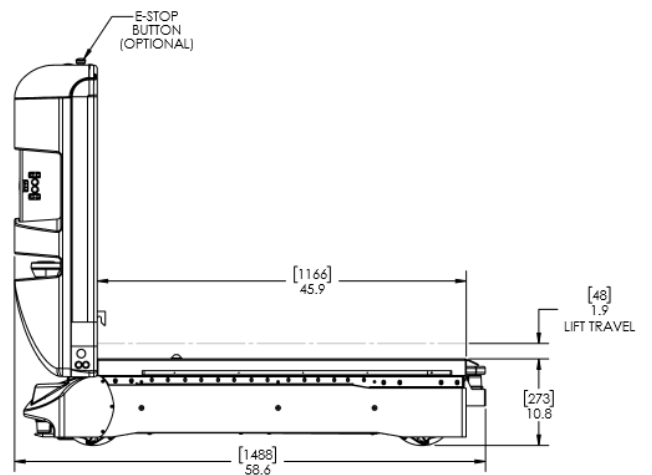
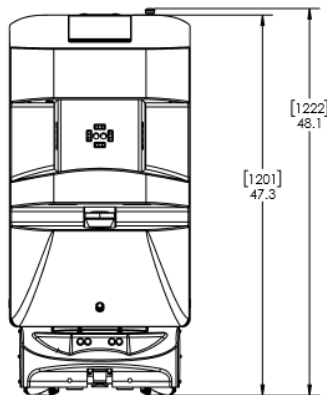
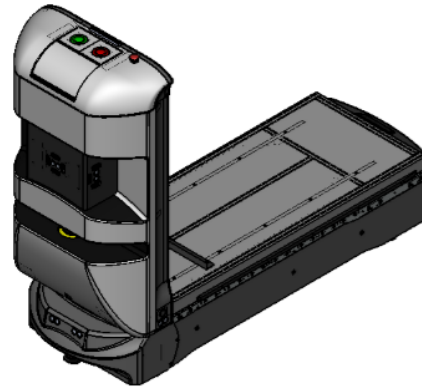
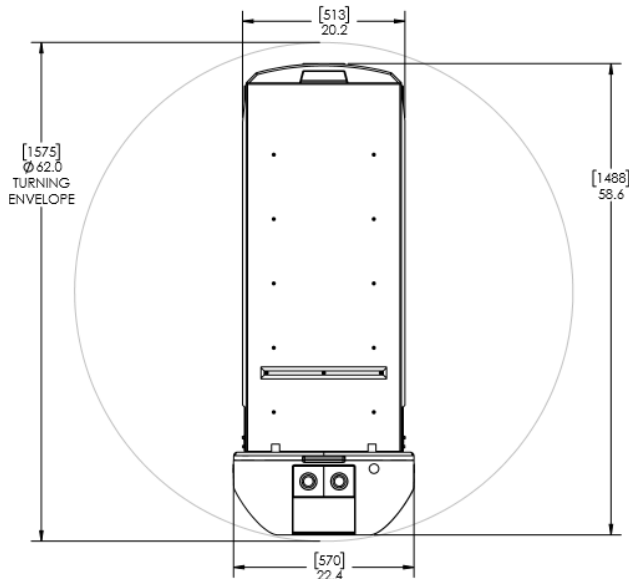

Copyright Aethon Inc 2017. All Rights Reserved. www.aethon.com
 Specifications subject to change.